

# LED Goldstar™ - D63

A complete range of non-maintained Emergency luminaires for commercial applications

## FEATURES

- Suitable for all emergency lighting applications
- Energy efficient: less than 1W energy consumption in stand by mode
- Suitable for different hole sizes
- One high Brightness LED
- T-sense™ temperature sensing technology for LIION battery
- Easy to install spring clips
- Available in black or white finish
- Standalone or MasterMinder emergency monitored
- Manufactured in Australia

## APPLICATIONS

- Commercial offices
- Shopping centre
- Facilities
- Public Building applications

## TECHNICAL INFORMATION

- Operating mode: Maintained
- Supply voltage: 240V a.c. +/- 6% 50Hz
- Operating voltage: 0.95W SPU/ 1.4W
- Battery: Li-ion 6.4V, 1.5Ah with PCM-BIP
- IP rating: IP20
- Body construction: Polycarbonate
- Operating temperature: 10°C to 40°C
- Compliance: AS/NZS 2293 AS/NZS 60598



No Trim



Small ring



Medium Ring



Medium square

Trim	Dimensions	Hole cut-out
No Trim	56MM	52MM Ø
Small ring	80MM	52MM-60MM Ø
Medium Ring	120MM	52MM-85MM Ø
Medium square	120X120MM	52MM-85MM Ø

SPU		
Cat No	Description	Classification C0/C90
F9994/LI	LED GOLDSTAR FLEX AND PLUG WHITE LITHIUM	D63
F9994/BL/LI	LED GOLDSTAR FLEX AND PLUG BLACK LITHIUM	D63

MasterMinder		
Cat No	Description	Classification C0/C90
FX9994/LI	LED GOLDSTAR FLEX AND PLUG WHITE LITHIUM	D63
FX9994/BL/LI	LED GOLDSTAR FLEX AND PLUG BLACK LITHIUM	D63

Spacing table: Maximum spacings between luminaires as per AS/NZS 2293

Mounting Height (m)	2.4	2.7	3	3.3	3.6	4.0
A	20.3	21.1	21.8	22.4	23.0	23.7
B	20.3	21.1	21.8	22.4	23.0	23.7

# LED Goldstar™ - D63



## DIMENSIONS

### Fascia

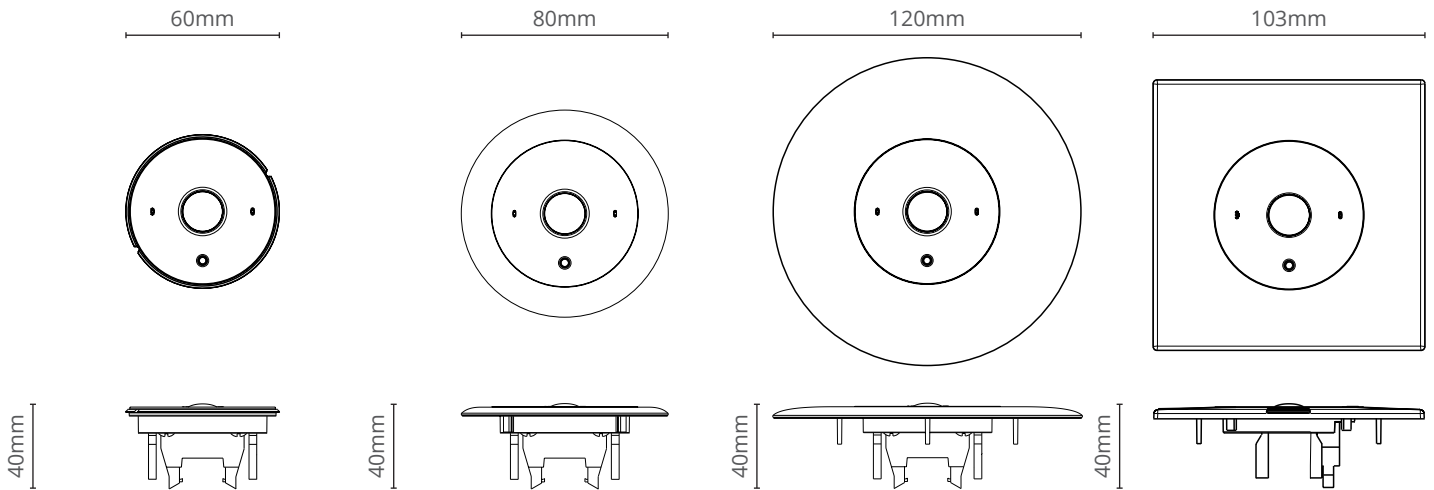

### SPU Power Pack

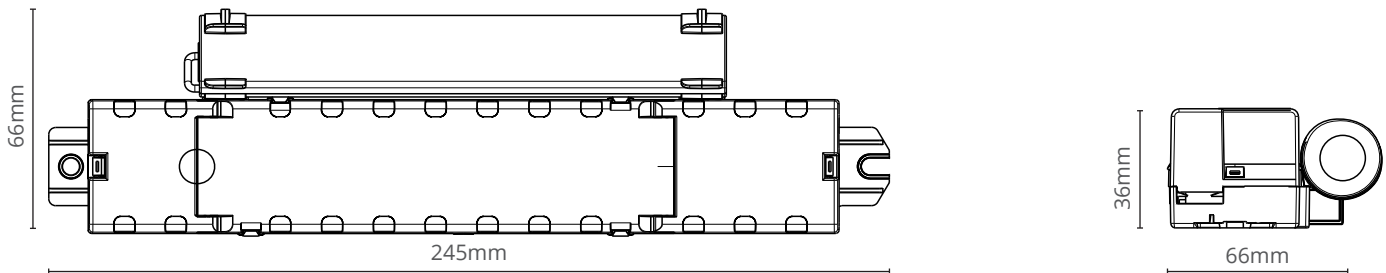

### MasterMinder Power Pack

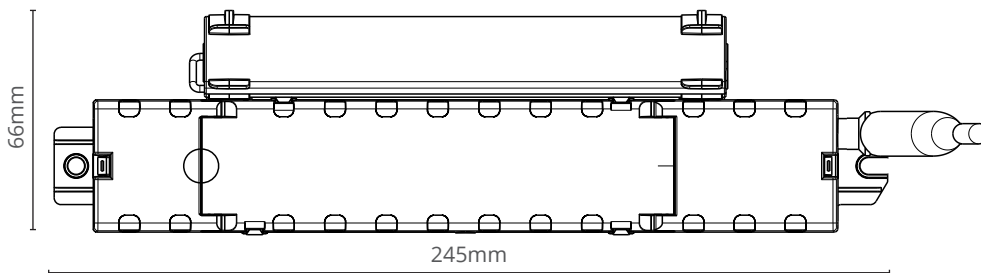

More info available at:  
[www.famco.com.au](http://www.famco.com.au)

**FAMCO LIGHTING PTY LTD**

T: (03) 9935 7300 F: (03) 9935 7301 E: [info@famco.com.au](mailto:info@famco.com.au) W: [www.famco.com.au](http://www.famco.com.au)

© 2016 Famco Lighting Pty Ltd. All rights reserved. E&OE. Subject to change without notice, to allow progress in design. This document and the information it contains is the property and copyright of Famco Lighting Pty Ltd and must not be used, copied, transmitted or reproduced without our written permission.