

Eco Rapid LED Exit

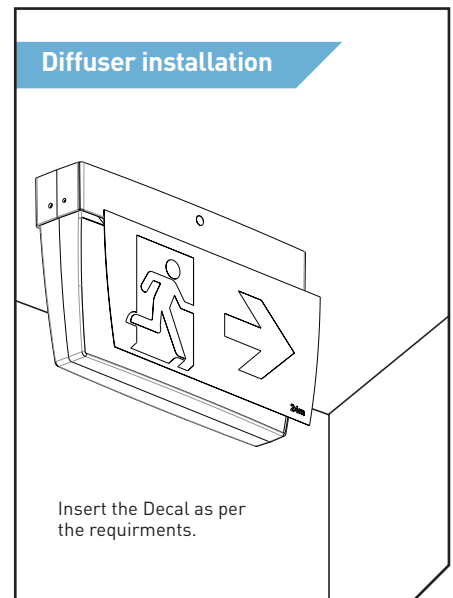

LUMINAIRE DESIGNERS, MANUFACTURERS & SUPPLIERS

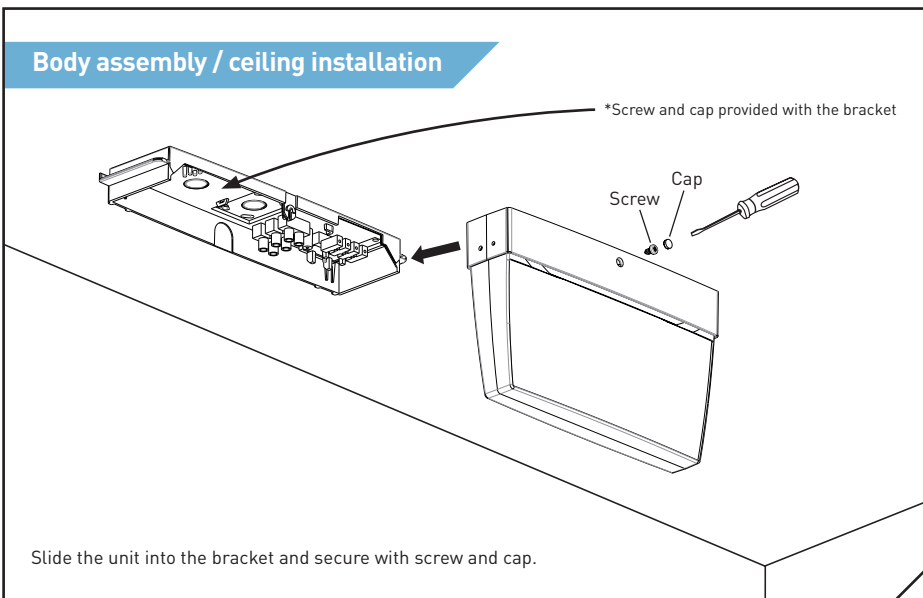
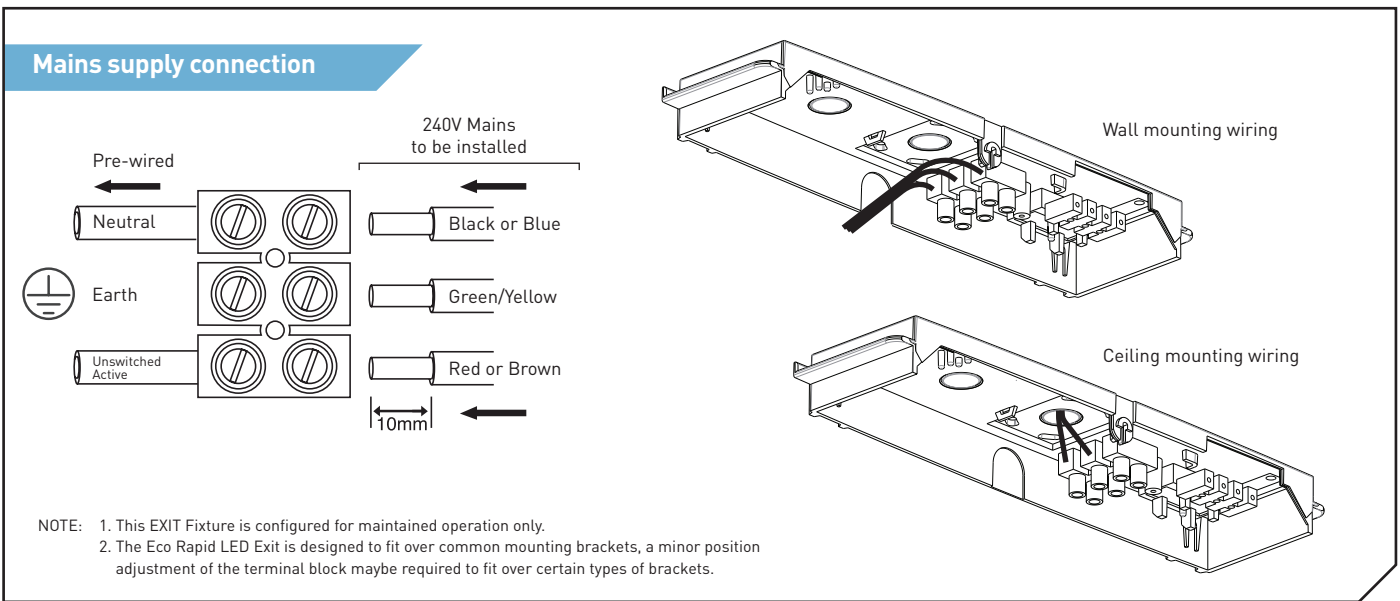
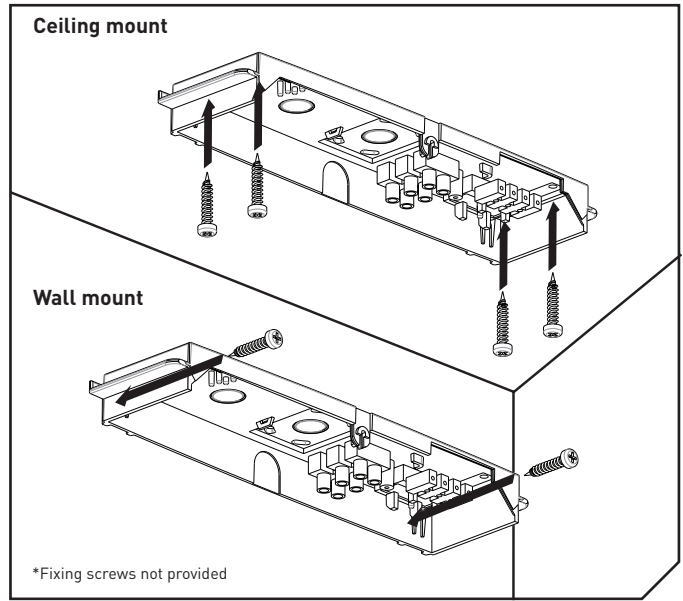
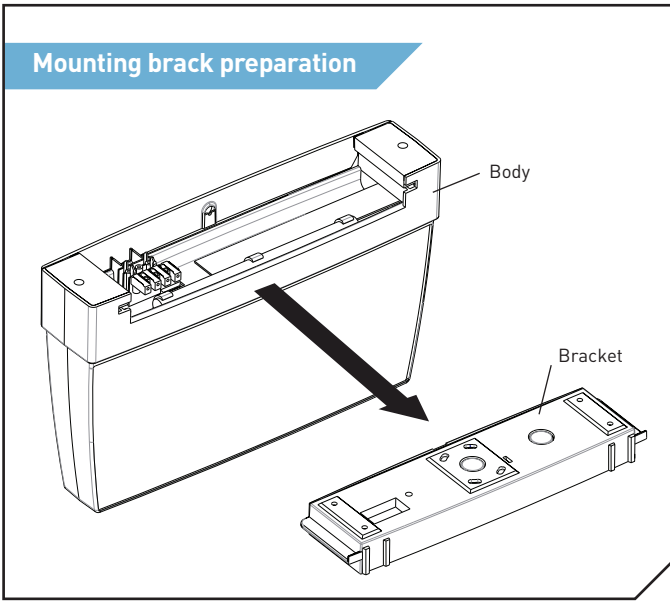

Important Notice

Famco recommends and advises that only suitably qualified personnel undertake installation and maintenance of this emergency lighting unit, and that the installation complies with relevant safety and electrical standards.

Status Indication

Battery charging LED

LED On:	Unit is fully charged OR Battery is charging.
LED Off:	Loss of mains power, OR Battery disconnection.

Installation Testing - with the unit connected to the unswitched mains supply, check that the charge indicator is illuminated. If not illuminated check that the supply is on, and that the battery leads in the unit are correctly connected. It is recommended that the batteries be charged for a minimum of 16 hours before a full discharge test is performed. However, checking of the emergency lamp function may be performed after 1 hour by momentarily pressing the test switch on the unit. Interrupting supply will Discharge Emergency Lighting Batteries. If supply remains interrupted for a long period, permanent damage to the batteries may result due to excessive battery discharge.

Do not subject units to a high number of charge/discharge cycles as can occur on temporary (construction) power supply.

Inspection and Maintenance - must be performed in accordance with AS/NZS2293-2 for Australian and New Zealand installations and in accordance with relevant local standards in other countries.

The **batteries** in this emergency lighting unit **MUST** be replaced when the unit no longer meets rated operating life.

Technical Data - for full technical or photometric data please consult Famco.

Disclaimer - This product should only be cleaned with a damp cloth. Cleaning agents and solvents should not be used. The IP rating of this product is only valid when all applicable seals, glands and their appropriate cables are installed correctly. This product must be installed and used as per these instructions. This product must be installed by a licenced electrician. After installation this product must be commissioned and tested as required by the appropriate government and/or statutory regulations. This product utilises intellectual property in the form of the registered designs, trademarks, and/or patents. Such intellectual property remains the property of Famco in all cases. Famco reserves their right to modify the specifications of this product at any time. This product must be used with the loads specified only. Other load types should be used only when written confirmation is given by Famco. This product contains rechargeable batteries. If this product is to be stored for an extended period of time (>3 months) then all batteries must be disconnected prior to storage. This product contains rechargeable batteries that may contain heavy metals. At the end of their life the batteries should be recycled. This product has no user serviceable part and no attempt should be made to repair this product. For repair please contact Famco. Extended exposure to UV rays (such as exposure to direct sunlight) may cause discolouration of this product. Severe electromagnetic interference from other products may cause malfunction of this product. This product is not suitable for marine environments such as areas subject to salt spray and/or mist. This product is not suitable for installation in hazardous and/or corrosive areas. The material in this product may vary in colour from batch to batch. Colour matching from one batch to another cannot be guaranteed. Electrical installations periodically received transient over voltages. This product has been designed to minimise the effect of such voltages on connected equipment. It may not give full protection for extreme over voltage transients such as those resulting from a close lighting strike. This product has been designed to operate on a nominal supply voltage of 230V - 6% to 240Va.c. + 6%. Performance of this product may be affected if installed near RF transmitters such as mobile phone services or similar. Performance of this product may be affected if installed in or around substantially metal enclosures or structures.

Warranty

Famco Lighting guarantees this lighting unit for a period of 36 months from date of despatch, solely against failure arising from faulty materials or workmanship, and provided that the unit has been stored, shipped, installed, used and maintained in accordance with the manufacturers instructions and relevant standards. Misuse, negligence or modification of the unit voids all warranties. Consult Famco Lighting Pty Ltd Conditions of Sale for details on warranty liability. If this lighting unit is faulty, return the unit freight pre-paid to your point of purchase, or contact Famco Lighting Pty Ltd on +61 (03) 9935 7300.

Customer Service

For all Customer Service and Technical Support enquires please call Monday to Friday during business hours.

Famco Lighting PTY LTD
+61 (03) 9935 7300
www.famco.com.au

ABN: 22 091 160 440