

Eco Rapid Mirage LED

ECO RAPID



FEATURES

- T-sense temperature sensing technology for the Li-ion battery.
- Electronics designed to lengthen the life of the battery, minimising maintenance costs.
- Recess trim included for recessed installations.
- Wall or Ceiling mount options.
- Easy slide bracket.
- One box solution.
- Environment friendly battery.
- Designed in Australia.



with Recess trim

APPLICATIONS

- Schools
- Offices
- Shopping Centres

TECHNICAL INFORMATION

- Operating Mode: Maintained
- Nominal Input Voltage: 230 - 240V a.c. 50Hz
- Power Consumption: 3W
- Inrush Current: 9.8 A peak
- Battery: Li-ion 6.4V, 0.57Ah
- Light Source Life (LSL): 50,000 hrs
- Operating Temperature: 10°C to 40°C
- Body and Diffuser Construction: Polycarbonate
- IP Rating: IP20
- IK Rating: IK03
- Compliance: AS/NZS 2293, AS/NZS 60598



Eco Rapid Mirage LED

ECO RAPID



DIMENSIONS

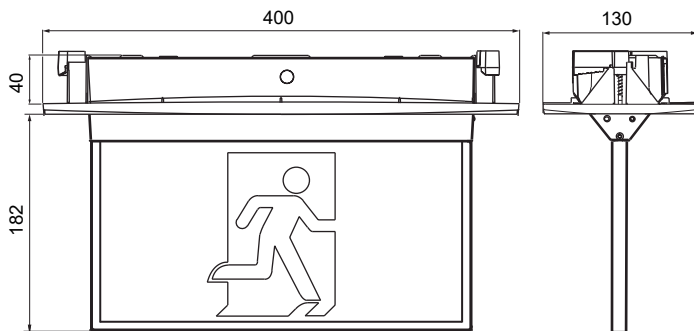

With recess trim

SPACING TABLE

Spacing Table: Maximum Spacing between luminaires for 0.2 lux (Australia)

Mounting Height (m)	2.7	3.0	3.3	3.6	4
C ₀ : B8	6.0	6.2	6.4	6.6	6.7
C ₉₀ : A20	6.8	7.2	7.5	7.8	8.2

As per AS/NZS 2293:2018

Spacing Table: Maximum Spacing between luminaires for 0.2 lux (Australia)

Mounting Height (m)	2.7	3.0	3.3	3.6	4
C ₀ : B8	3.0	0.0*	0.0*	0.0*	0.0*
C ₉₀ : A20	4.3	4.4	4.4	4.4	4.4

As per AS/NZS 2293:2018

* - exit sign satisfies the requirement to illuminate the doorway or potential hazard, however without a spacing for this mounting height as per AS/NZS 2293.1 clause 4.5.

Cat. No.	Description
F9971/LI	MAINTAINED LED SET OF 3 X RM DECALS SS/DS - LI-ION
ACCESSORIES	
F9918/SUSP	WIRE SUSPENSION KIT (2 X 6M)
FEXROD/600	SUSPENSION ROD KIT - 600 MM - WHITE
FEXROD/1200	SUSPENSION ROD KIT - 1200 MM - WHITE
FEXROD/3000	SUSPENSION ROD KIT - 3000 MM - WHITE

RM= Running Man, DS= Double Sided, SS= Single sided

Note: All dimensions are in mm.

FAMCO LIGHTING PTY LTD

T: (03) 9935 7300 F: (03) 9935 7301 E: info@famco.com.au W: www.famco.com.au

© 2019 Famco Lighting Pty Ltd All rights reserved. E&OE. Subject to change without notice, to allow progress in design. This document and the information it contains is the property and copyright of Famco Lighting Pty Ltd and must not be used, copied, transmitted or reproduced without our written permission.

