

Eco Rapid LED Site Guard

ECO RAPID



A complete range of non-maintained Emergency luminaires for commercial applications.

FEATURES

- Electronics designed to lengthen the life of the battery, minimizing maintenance costs.
- T-Sense temperature sensing technology for the Li-ion battery.
- Energy efficient LED lamp technology.
- Environment friendly battery.
- Easy to install
- 3 Year Warranty.
- Designed in Australia.

APPLICATIONS

- Loading Docks
- Small Gymnasiums
- Car Parks



TECHNICAL INFORMATION

- Operating Mode: Non-Maintained
- Nominal Input Voltage: 230-240V a.c. 50Hz
- Power Consumption: 3W
- Inrush Current: 4A peak
- Battery: Li-ion 3.2V, 6.6 Ah
- Lumen Output: 2x 180 lm
- Light Source Life (LSL): 50,000 hours
- Operating Temperature: 10°C to 40°C
- IP Rating: IP65
- IK Rating: IK07
- Body and Diffuser Construction: Polycarbonate
- Compliance: AS/NZS 2293, AS/NZS 60598



Cat. No.	Description
F9979/LI	Eco Rapid LED Site Guard
Accessories	
FL9930WG	Wire Guard - White

Eco Rapid LED Site Guard

ECO RAPID



LUX PLOT

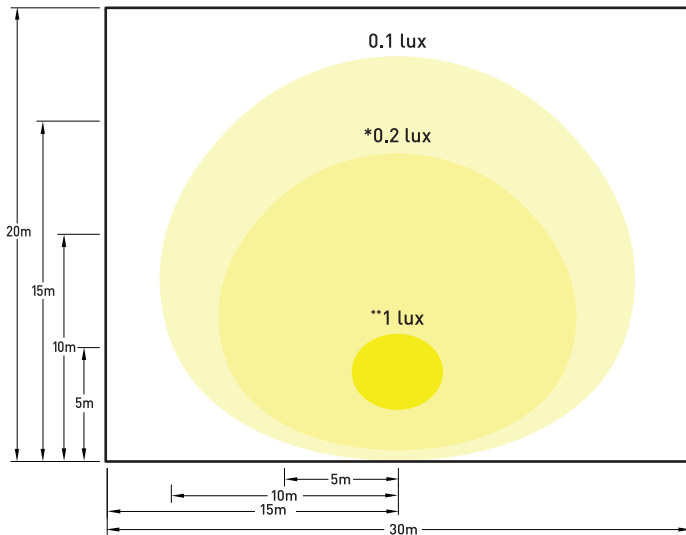

- Luminaire is mounted 5m above floor on one wall.
- Spotlights have a 90 degree tilt angle (straight out from fitting)
- A maintenance factor of 1.0 is applied to all luminaires.
- Illuminance measurements are at ground level.
- This design is to be used as a guide only and should not be used for compliance. A dedicated lighting design will need to be done for every application.

*0.2 lux corresponding to Australian lighting standards.

**1.0 lux corresponding to New Zealand lighting standards.

DIMENSIONS

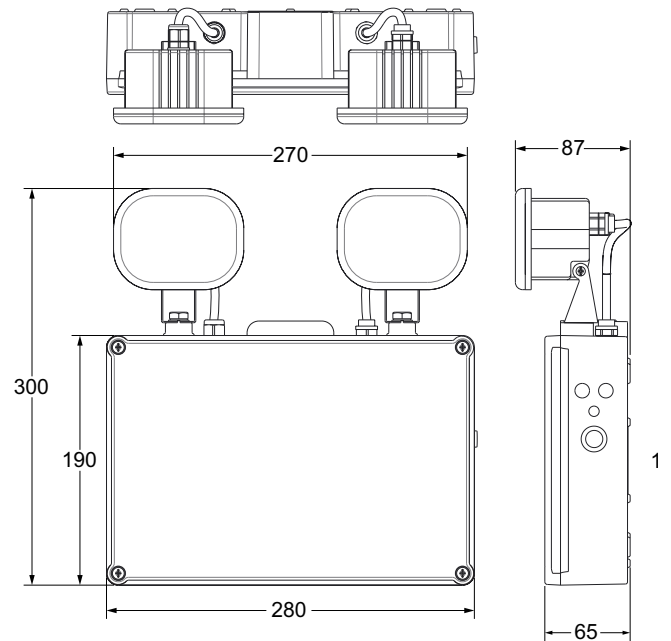

Note: All dimensions are in mm.

More info available at:
www.famco.com.au

FAMCO LIGHTING PTY LTD

T: (03) 9935 7300 F: (03) 9935 7301 E: info@famco.com.au W: www.famco.com.au

© 2019 Famco Lighting Pty Ltd All rights reserved. E&OE. Subject to change without notice, to allow progress in design. This document and the information it contains is the property and copyright of Famco Lighting Pty Ltd and must not be used, copied, transmitted or reproduced without our written permission.

